

# THE ROGUE™ GRAND RAPIDS™ ASSEMBLY AND INSTALLATION INSTRUCTIONS



CORPORATE HEADQUARTERS  
WESTERN SALES AND MANUFACTURING PLANT  
P.O. Box 400 • 1017 SW Berg Parkway  
Canby, Oregon 97013  
(503) 266-2231 • (503) 266-4334

[www.srsmith.com](http://www.srsmith.com)

## Table of Contents

<u>Topic</u>	<u>Page #</u>
Introduction.....	2
Applicable Standards and Codes.....	2
Assembly and Installation.....	2
Drawings.....	2
Parts List .....	3
Slide Deck Anchor Flange Kit.....	4
Tools Required For Assembly List.....	4
Left Curve Footprint.....	5
Right Curve Footprint.....	6
Left Curve Slide with Flush Deck Mounting.....	6
Assembly Instructions for In-Deck Mounting.....	7
Assembly Instructions for Flush Deck Mounting.....	17
Manufacturer's Placement Instructions.....	18
Electrical Bonding.....	20
Installed Slide's Structural & Installation Checklist.....	20

## INTRODUCTION

S.R. Smith Rogue™ Grand Rapids™ is manufactured for installation and use on residential in ground swimming pools only. S.R. Smith Rogue™ Grand Rapids™ is NEVER to be installed and used on public in ground pools, aboveground pools, on ground pools, houseboats, boat docks, floating docks or platforms.

## APPLICABLE STANDARDS AND CODES

1. All S.R. Smith Rogue™ Grand Rapids™ are manufactured in accordance with Consumer Products Safety Commission STANDARD FOR SWIMMING POOL SLIDES, 16 CFR Ch. 11 Part 1207 (latest edition).
2. Installer must comply with all applicable governmental and building codes.

## ASSEMBLY AND INSTALLATION

All S.R. Smith Rogue™ Grand Rapids™ are inspected prior to shipment from the factory. Proper assembly and installation is mandatory. Improper assembly and installation voids S.R. Smith's warranty and may affect the safety of the user. S.R. Smith cannot and does not guarantee customer's concrete deck.

## DRAWINGS

All drawings in these Assembly and Installation Instructions are for illustration purposes only and are NOT TO SCALE.

## PARTS LIST

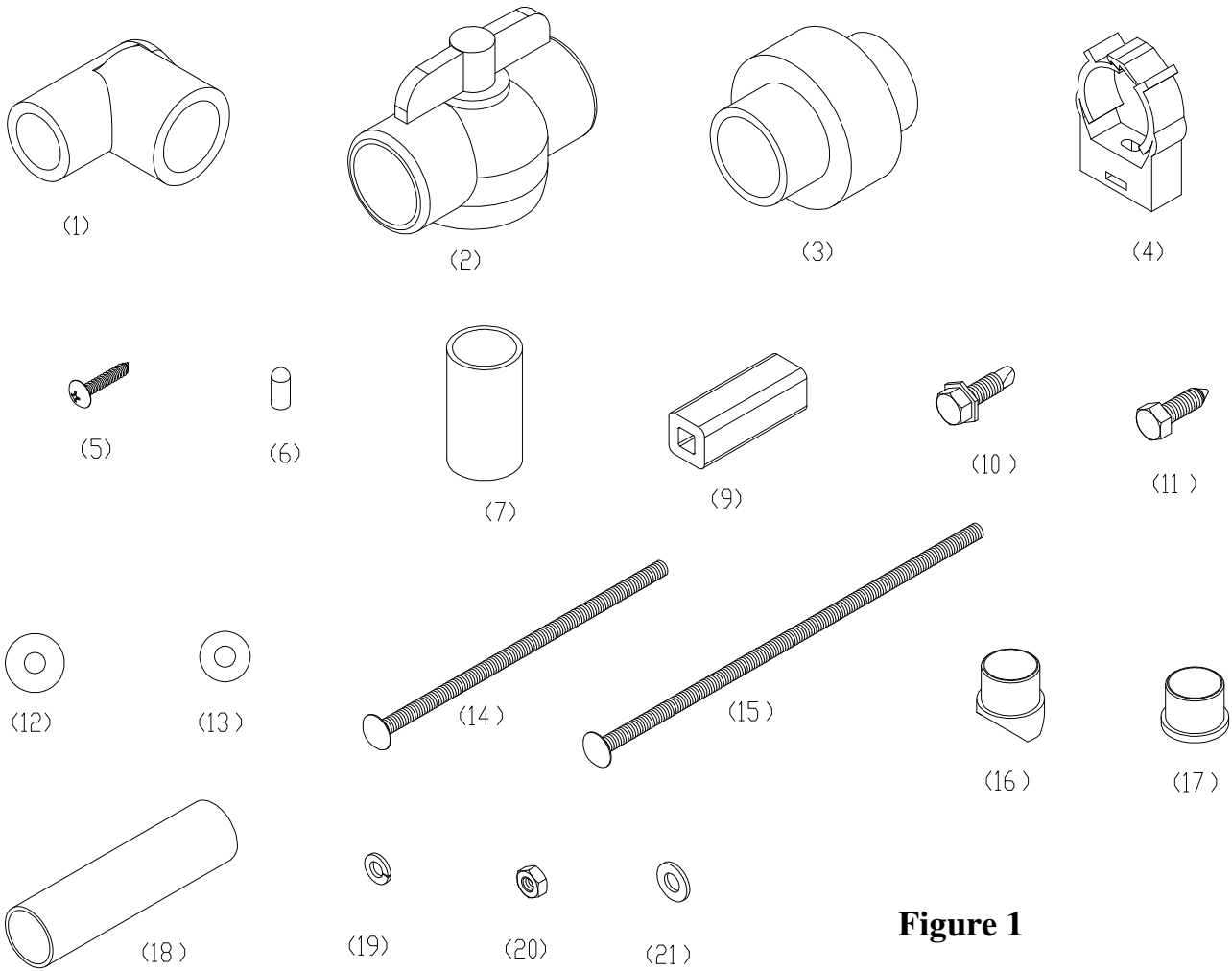
Before getting started check to make sure that all of the parts listed below arrived with your new S.R. Smith Rogue™ Grand Rapids™ slide.

Ref # *	PART #	DESCRIPTION	QTY
1	05-792	1" PVC 90 Elbow ST SCH 40 SXS	1 ea.
2	05-766	PVC Ball Valve SCH 80 SXS	1 ea.
3	05-769	PVC Union SCH 40 1" SXS	1 ea.
4	05-767	Plastic Pipe Clamp for 1" SCH 40	6 ea.
5	5-371	Self Tapping Screw #10-16 x 1" S/S	6 ea.
6	05-668	Vinyl Cap .172 ID x .5 LG.	6 ea.
7	1-311-1	1" PVC Nipple, 2" Long	1ea.
8	05-771-1	PVC Spa Hose 1" ID x 1.125" OD (Not Shown)	8 ft.
9	01-210	Aluminum Ladder Spacer	2 ea.
10	05-31-110S	5/16" x 1" Hex Washer Head Tek Screw S/S	4 ea.
11	05-14-101S	5/16 " x 1" Lag Screw S/S	2 ea.
12	05-14-102	5/16" x 7/8" Flat Washer	2 ea.
13	05-622	5/16" x 3/4" Black Rubber Washer	2 ea.
14	05-31-151	1/4-20 x 6" Carriage Bolt S/S	4 ea.
15	05-31-149	1/4-20 x 8" Carriage Bolt S/S	2 ea.
16	6-121	Nylon Tube Connector	6 ea.
17	6-123	Nylon Handrail Connector	6 ea.
18	01-212	Aluminum Handrail Spacer	6 ea.
19	5-149	1/4" Lock Washer S/S	8 ea.
20	5-137	1/4-20 Hex Nut S/S	8 ea.
21	05-14-111	1/4 x 5/8 Flat Washer	8 ea.
22	05-14-124	1/4" x 1/2" Sheet Metal Screw (Not Shown)	5 ea.
23	05-143	1/4" x 3/4" Flat Washer C/S (Not Shown)	5 ea.
<b><u>SLIDE DECK ANCHOR FLANGE KIT</u></b> <b><u>(OPTIONAL – FOR FLUSH DECK MOUNTING)</u></b>			
24	**	Deck Anchor Flange	
25	04-14-111	1/4 X 5/8 Flat Washer	8 ea.
26	05-14-117	1/4-20 UNC Hex Nylon Locking Nut	4 ea.
27	05-14-123	1/4-20 UNC x 2-3/4 Hex Head Cap Screw	4 ea.
28	05-162	5/16-18 UNC x 2-3/4 Stud W/ Nut and Flat Washer	20 ea.
29	06-622	Anchor Flange Installation Instructions	1 ea.
30	01-500	3/8" O.D. Aluminum Bushing	4 ea.
31	5-306	5/16" lock Washer Split, S/S	20ea.

\* Ref #s are shown as (#\_\_ ) in these ASSEMBLY AND INSTALLATION INSTRUCTIONS

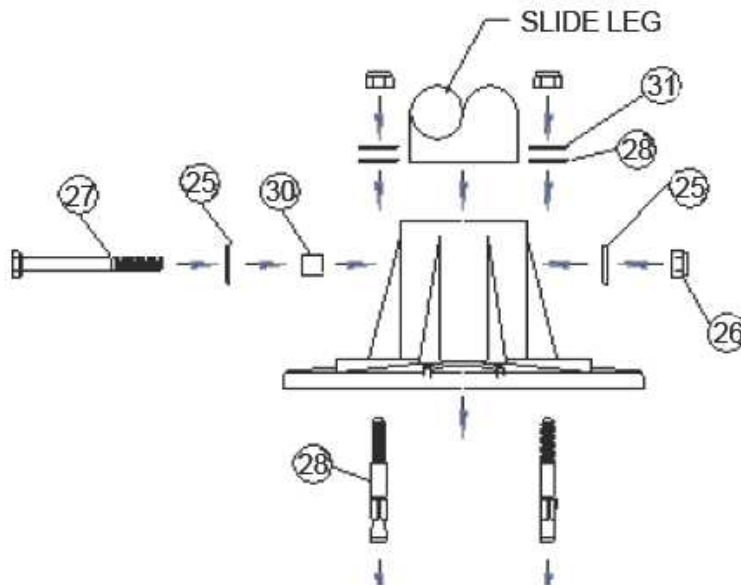
\*\* Deck anchor flanges are available in plastic (05-623) or aluminum (75-209-5000).

**ROGUE GRAND RAPIDS PARTS**



**Figure 1**

**SLIDE DECK ANCHOR FLANGE KIT PARTS(OPTIONAL – FOR FLUSH DECK MOUNTING)**

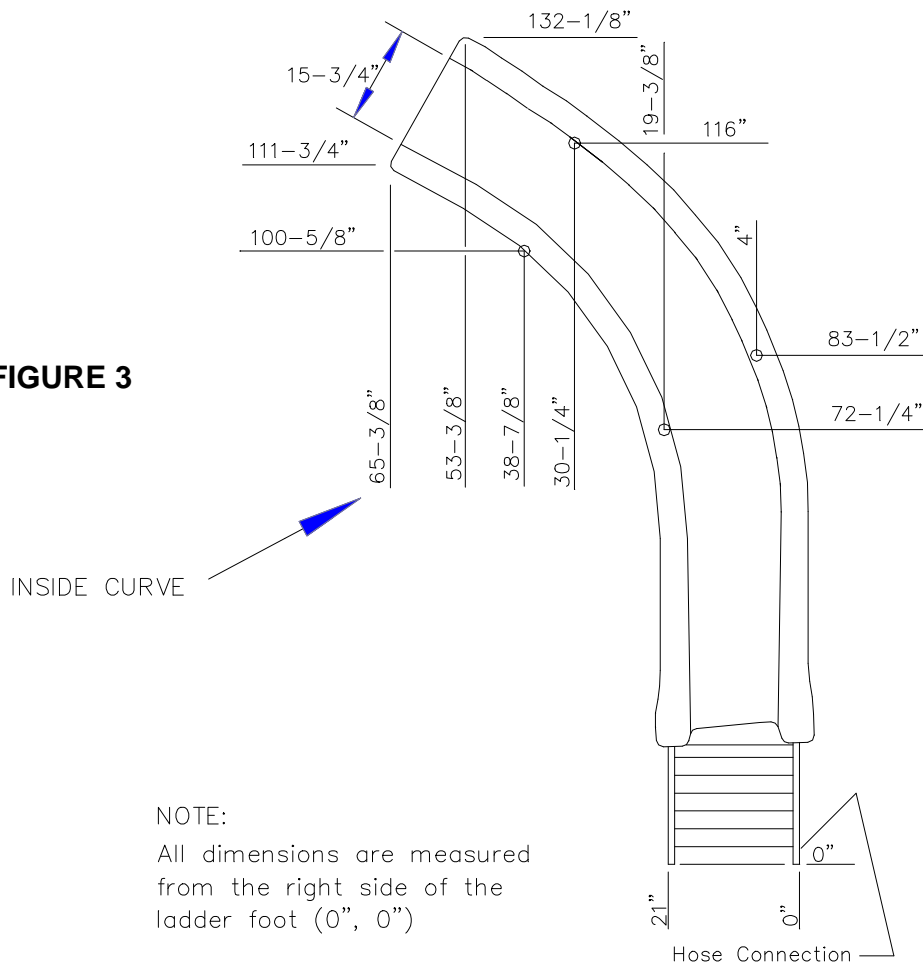


**Figure 2**

**TOOLS REQUIRED FOR SLIDE ASSEMBLY:**

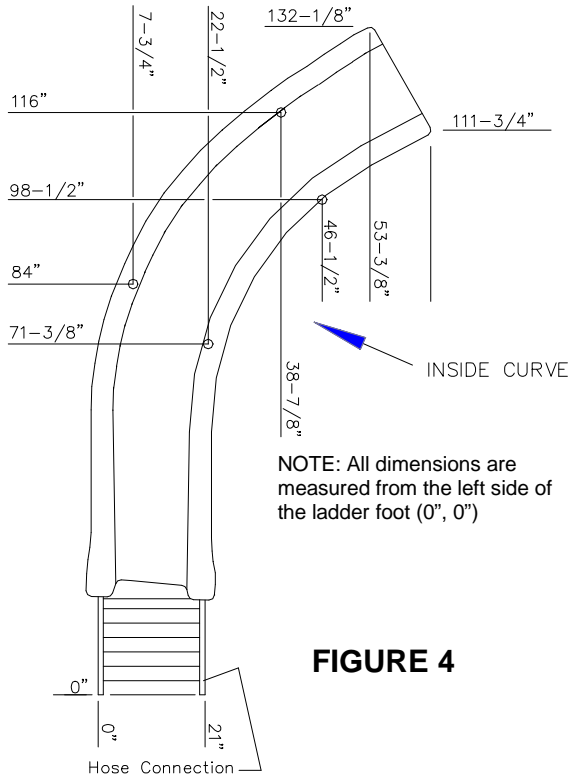
- PVC glue
- Silicon sealant
- Hand drill with Phillips bit
- Ratchet with 7/16", 1/2" and 3/8" sockets
- 7/16" wrench
- 1/2" wrench
- Hammer drill with 1/4" masonry bit
- Small Level

**FIGURE 3**



## LEFT CURVE FOOTPRINT

The purpose of this footprint is to serve as a GUIDELINE ONLY for approximate placement of the slide relative to the pool's edge. The actual dimensions after installation may vary according to the slope of the deck and the angle that the slide is oriented relative to the pool wall. **YOU MUST FOLLOW THE INSTALLATION INSTRUCTIONS AS PRINTED IN THIS MANUAL.**



**FIGURE 4**

## RIGHT CURVE FOOTPRINT

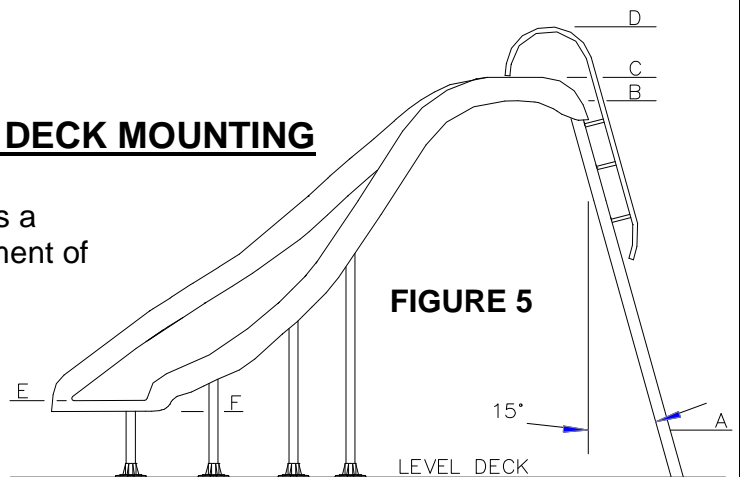
The purpose of this footprint is to serve as a GUIDELINE ONLY for approximate placement of the slide relative to the pool's edge.

The actual dimensions after installation may vary according to the slope of the deck and the angle that the slide is oriented relative to the pool wall.

**YOU MUST FOLLOW THE INSTALLATION INSTRUCTIONS AS PRINTED IN THIS MANUAL.**

## LEFT CURVE SLIDE WITH FLUSH DECK MOUNTING

The purpose of this side view is to serve as a GUIDELINE ONLY for approximate placement of the slide relative to the deck. The actual dimensions after installation may vary according to the slope of the deck and the angle that the slide is oriented relative to the pool wall. When installing the slide in the deck, these dimensions will be reduced by at least 3-1/8 inches.



**FIGURE 5**

### HEIGHT ABOVE DECK LEVEL OF:

- (A) Bottom of first ladder step:
- (B) Top runway surface:
- (C) Top runway side rail:
- (D) Top of handrail:
- (E) Exit runway surface:
- (F) Bottom of slide at exit end:

### LEFT CURVE

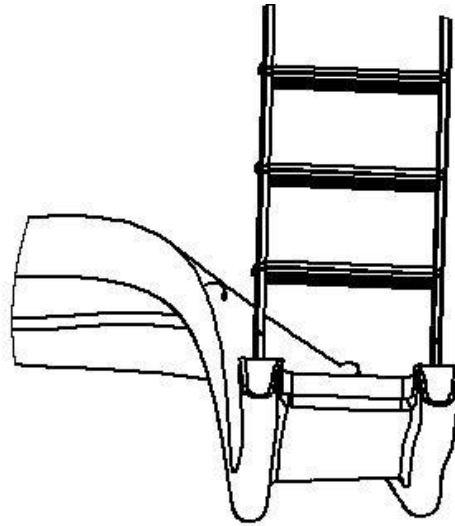
- 11-1/2"
- 78-3/8"
- 83-3/4"
- 94-3/4"
- 12-7/8"
- 11-1/8"

### RIGHT CURVE

- 11-5/8"
- 78-1/2"
- 83-3/4"
- 94-3/4"
- 14"
- 11-7/8"

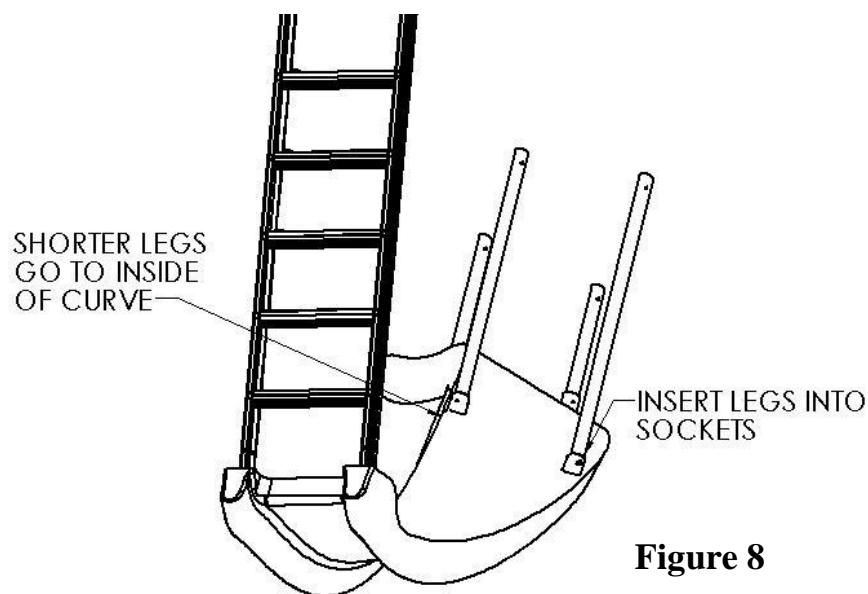
## **ASSEMBLY INSTRUCTIONS FOR IN-DECK MOUNTING**

- 1) Place the slide runway upside down on a surface that will not scratch the slide.
- 2) Open the ladder and parts carton and locate the ladder and the 4 legs.
- 3) Insert the top of the slide ladder all the way into the two sockets in the slide.  
NOTE: The top of the ladder is the end with the side rails cut square. See Figure 7.



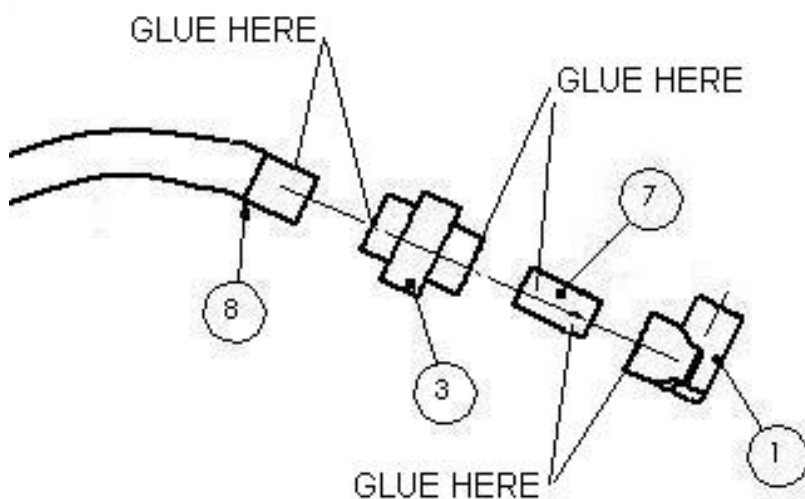
**Figure 7**

- 4) Insert the slide legs into the leg sockets of the slide. The shorter legs go into the sockets on the inside curve of the slide. Be sure to insert the end of the legs that do not have the pre-drilled holes into the leg sockets. Do not attach the legs permanently at this point. See Figure 8.



**Figure 8**

- 5) Carefully turn the slide with the legs and ladder upright for setup. It will be necessary for two people to perform this to avoid damage to the slide and the legs. If necessary use something such as tape to temporarily hold the legs in place while turning the slide over.
- 6) Place the slide at the desired location relative to the pool wall. See MANUFACTURER'S PLACEMENT INSTRUCTIONS on pages 18 & 19.
- 7) Ensure that the exit runway surface does not exceed 20 inches above the water surface, nor less than 8 inches above the deck/coping surface (see Figure 27 on page 18). The exit runway surface is measured at the point of transition between the runway and the beginning of the exit end radius.
- 8) Ensure that the ladder is not twisted relative to the slide.
- 9) Insert 3/8" diameter rebar (not provided) into the holes located at the bottom of each leg making sure that the rebar will be a minimum of three inches (3") below the deck surface.
- 10) Install electrical bonding as local code specifies (see ELECTRICAL BONDING page 20).
- 11) Secure the ladder so that the ladder steps are level, from side to side, and the ladder is sloped 15 degrees from vertical.
- 12) Use PVC glue to assemble the plumbing components as shown below in Figure 9. Use caution not to apply glue to the threaded joint of the (#3) union; the union is designed to be disassembled for winterizing.



**Figure 9**



- 13) Allow sufficient time for the glue to cure before moving on to the next step. The glued assembly is shown in Figure 10.

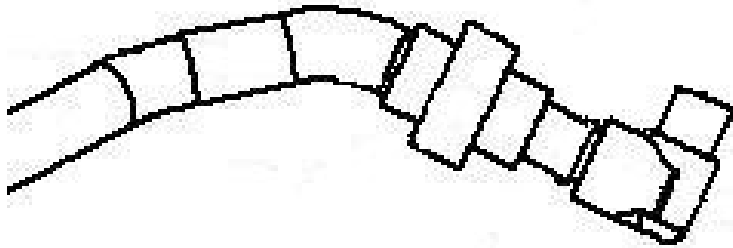


Figure 10

- 14) Apply PVC glue to the male slip end of the (#1) 90 degree elbow and insert the plumbing assembly from step 13 into the fitting in the bottom of the runway. It is important that the assembly be attached to the slide in the orientation shown in Figures 11 and 12, with the hose towards the ladder. sufficient time for the glue to cure before moving on to the next step.

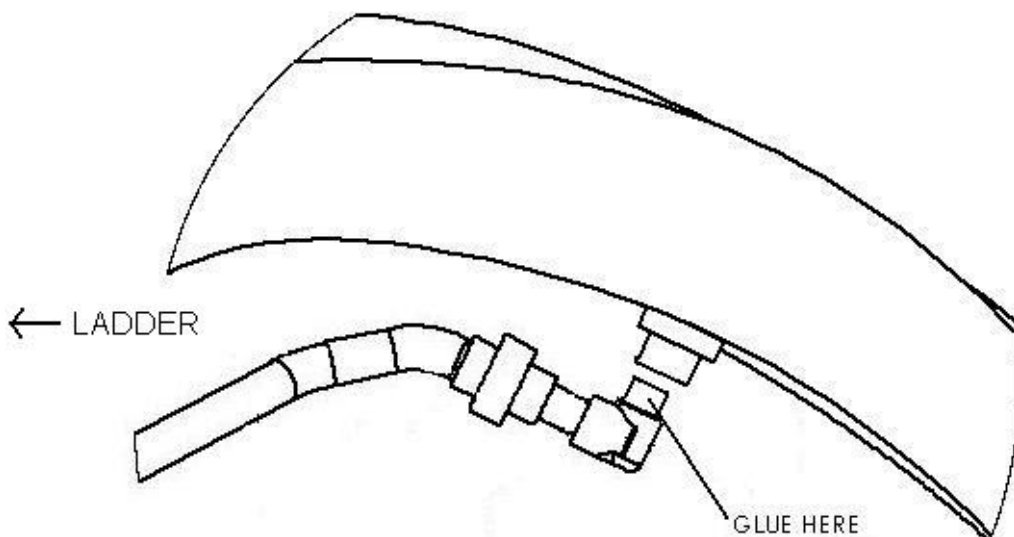
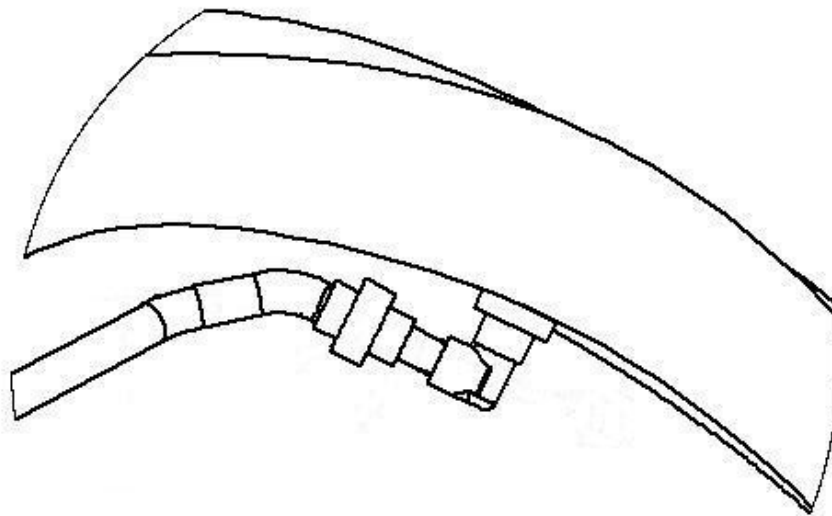
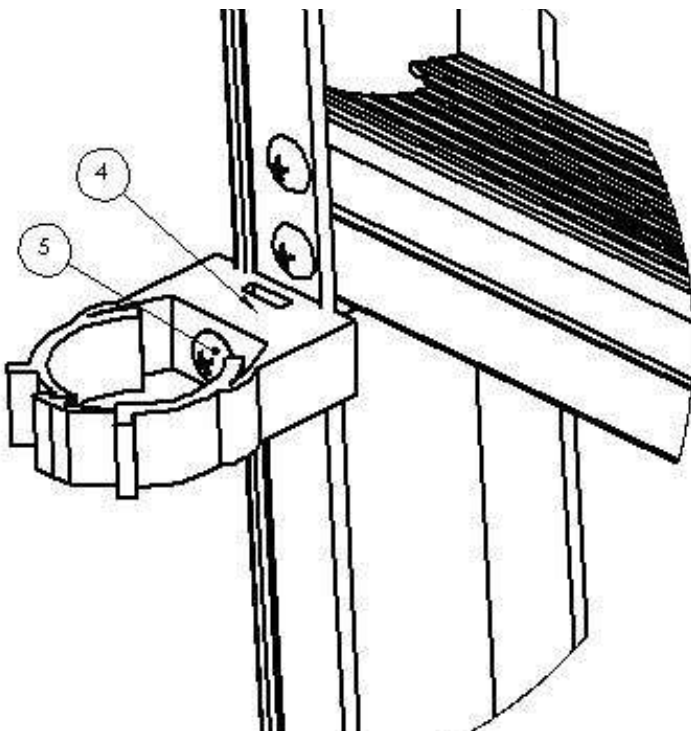


Figure 11

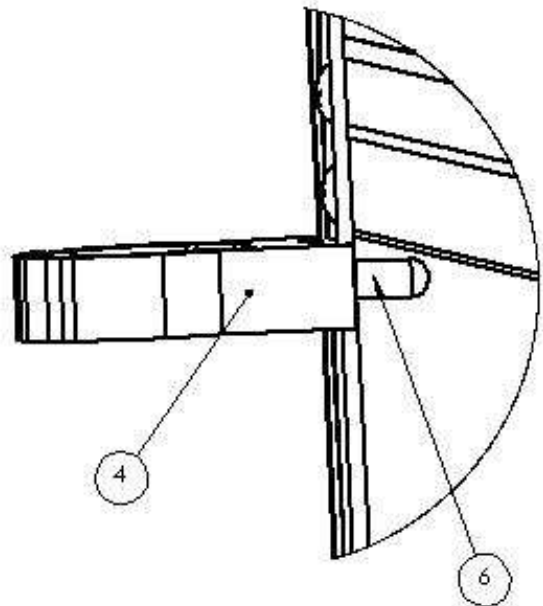


**Figure 12**

**15)** Use a drill with a Phillips bit to fasten the (#4) Plastic Pipe Clamp to the ladder as shown below in Figure 13a. The hose clamp should be attached with the clamp aligned with the bottom of the step, See Figure 13b. Place (#6) Vinyl Cap over visible portion of screw. Repeat this step for each tread on ladder.

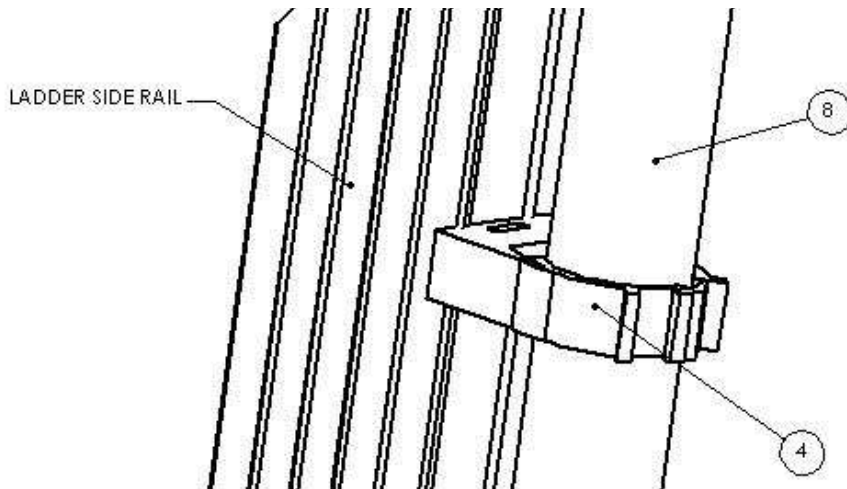


**Figure 13a**



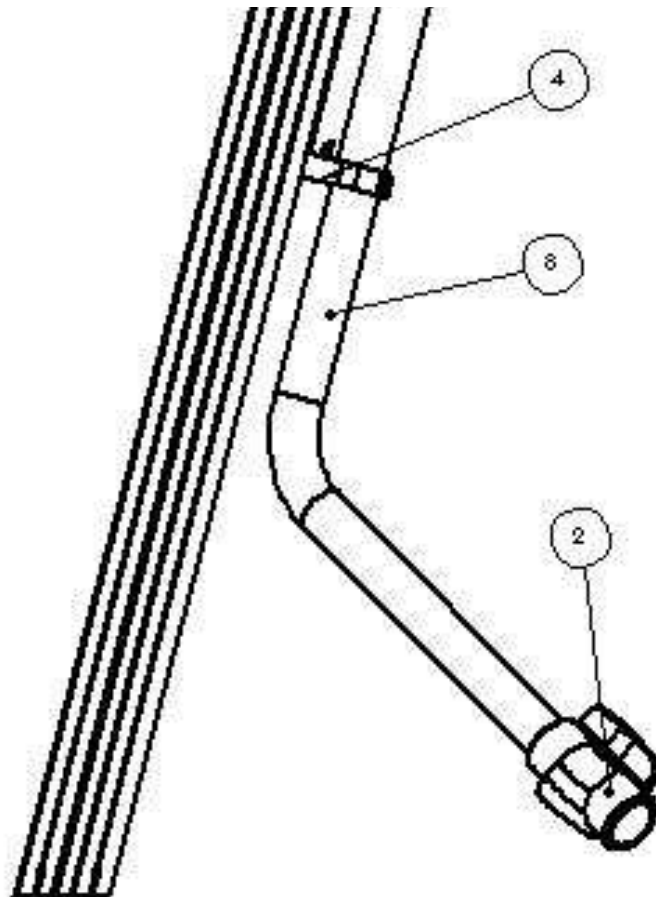
**Figure 13b**

- 16) Starting with the top hose clamp, insert the PVC hose into the clamps as shown below in Figure 14. The clamps automatically tighten when pressure is applied pushing the hose into the clamps.



**Figure 14**

- 17) Apply PVC glue to one socket of the (#2) PVC Ball Valve and insert the PVC hose into the valve as shown in Figure 15. Allow the glue sufficient time to dry. The final step is joining the PVC Ball Valve to the water source.

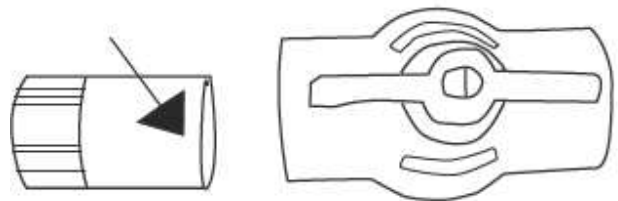


**Figure 15**

## Garden Hose Adapter Installation Instructions

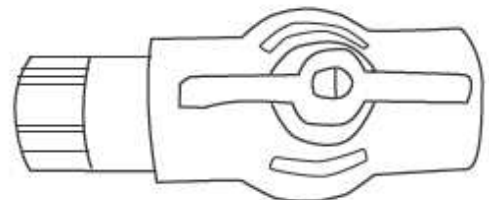
If connecting the Rogue™ Grand Rapids™ water system to the pool plumbing system is not an option you may connect the water system to a garden hose by following the steps outlined below.

A.) Make sure that the Rogue™ Grand Rapids™ water system has been properly assembled as explained in the Rogue™ Grand Rapids™ Installation Instructions. Next, apply PVC glue around the end of the garden hose adapter indicated by the arrow in Figure 16.



**Figure 16**

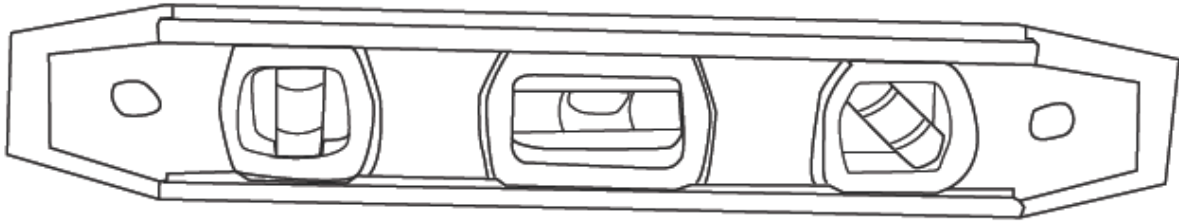
B.) After the glue is applied quickly insert the PVC fitting into one end of PVC ball valve as shown in Figure 17.



**Figure 17**

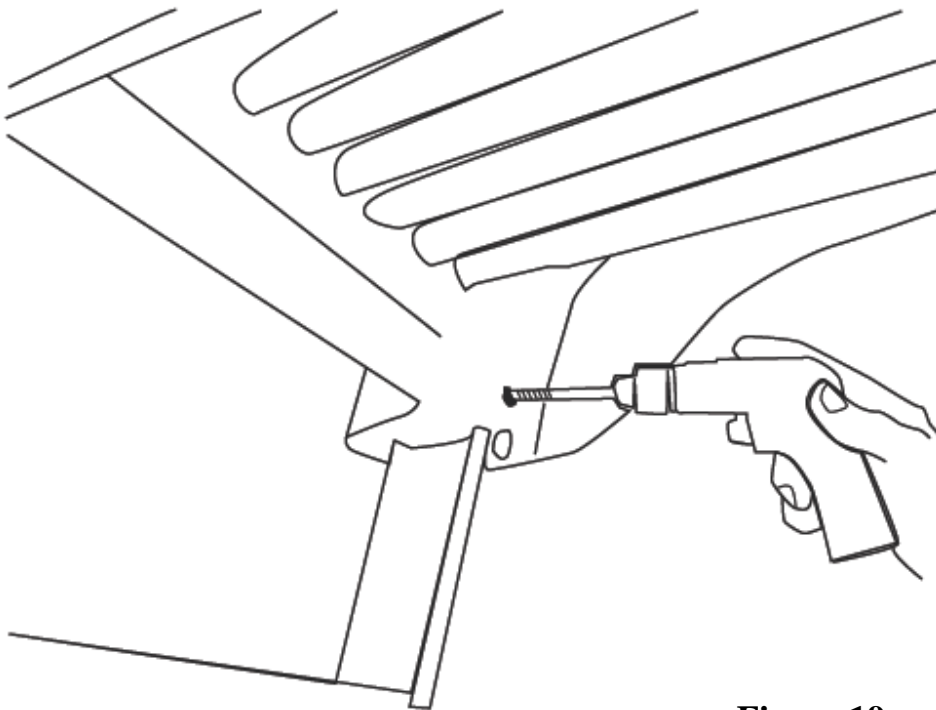
C.) The final step is to thread a garden hose into the PVC garden hose adapter.

- 18)** Adjust the top runway of the slide so that it is level, from side to side and lengthwise as shown below in Figure 18.



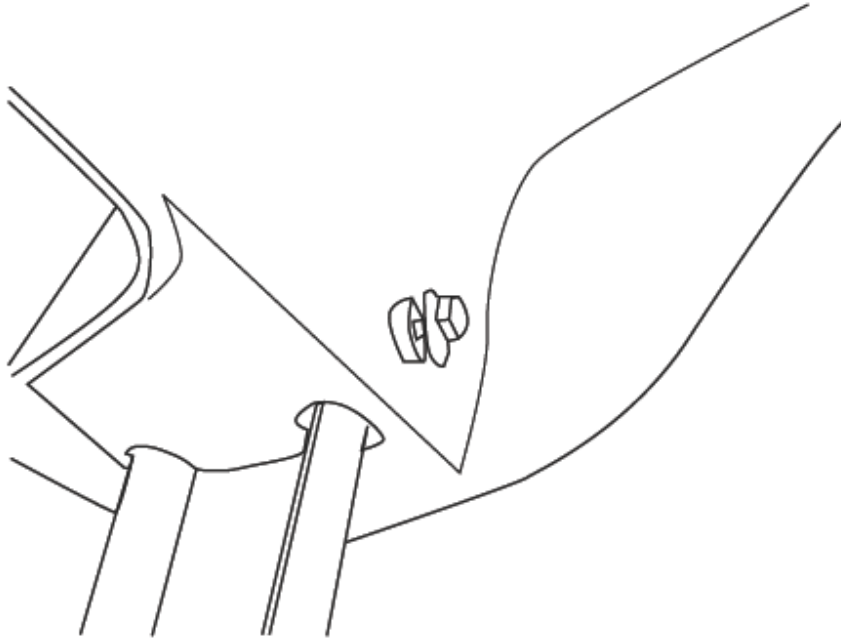
**Figure 18**

- 19)** Underneath the top portion of the slide, on the inside flat surface next to the ladder socket, use the existing holes as a template to drill a 1/4-inch hole through each ladder side rail as shown below in Figure 19.



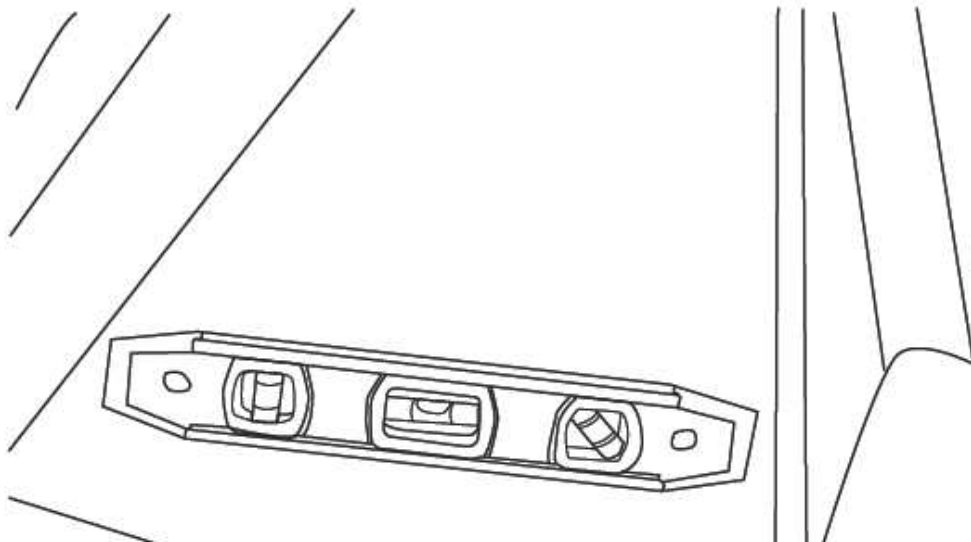
**Figure 19**

- 20)** To secure the ladder to the slide screw into the previously drilled holes (one per side rail) a (#11) 5/16" x 1" lag screw, a (#12) 5/16" x 7/8" flat washer and a (#13) 5/16" x 3/4" rubber washer tightening to 8 ft.-lbs of torque. See Figure 20.  
**CAUTION: DO NOT OVER TIGHTEN.**



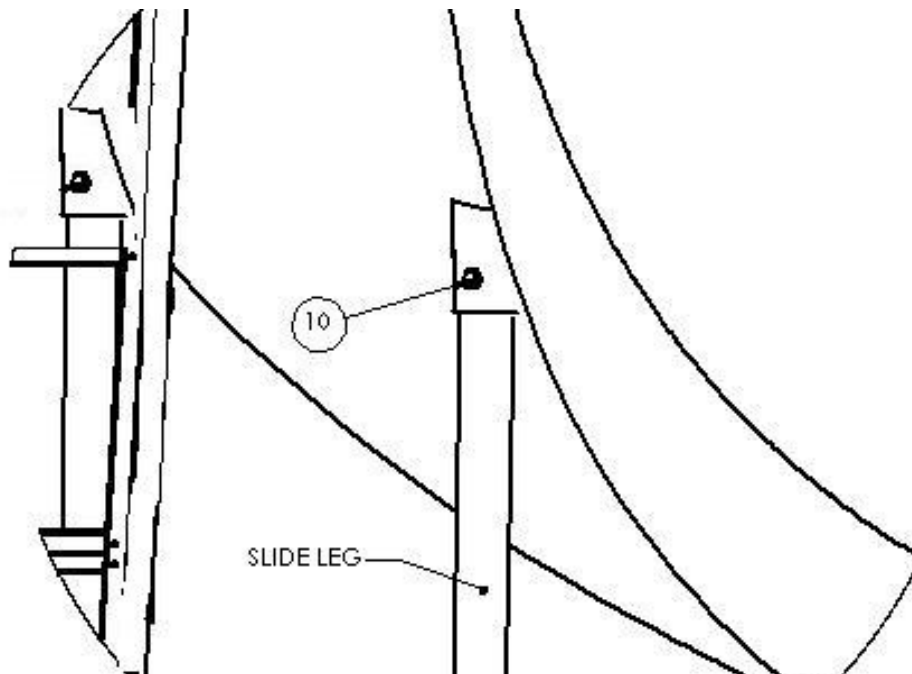
**Figure 20**

- 21)** Level as close as possible the exit runway surface horizontally from side to side, approximately 9" up from the exit end, using a small level as shown in Figure 21.



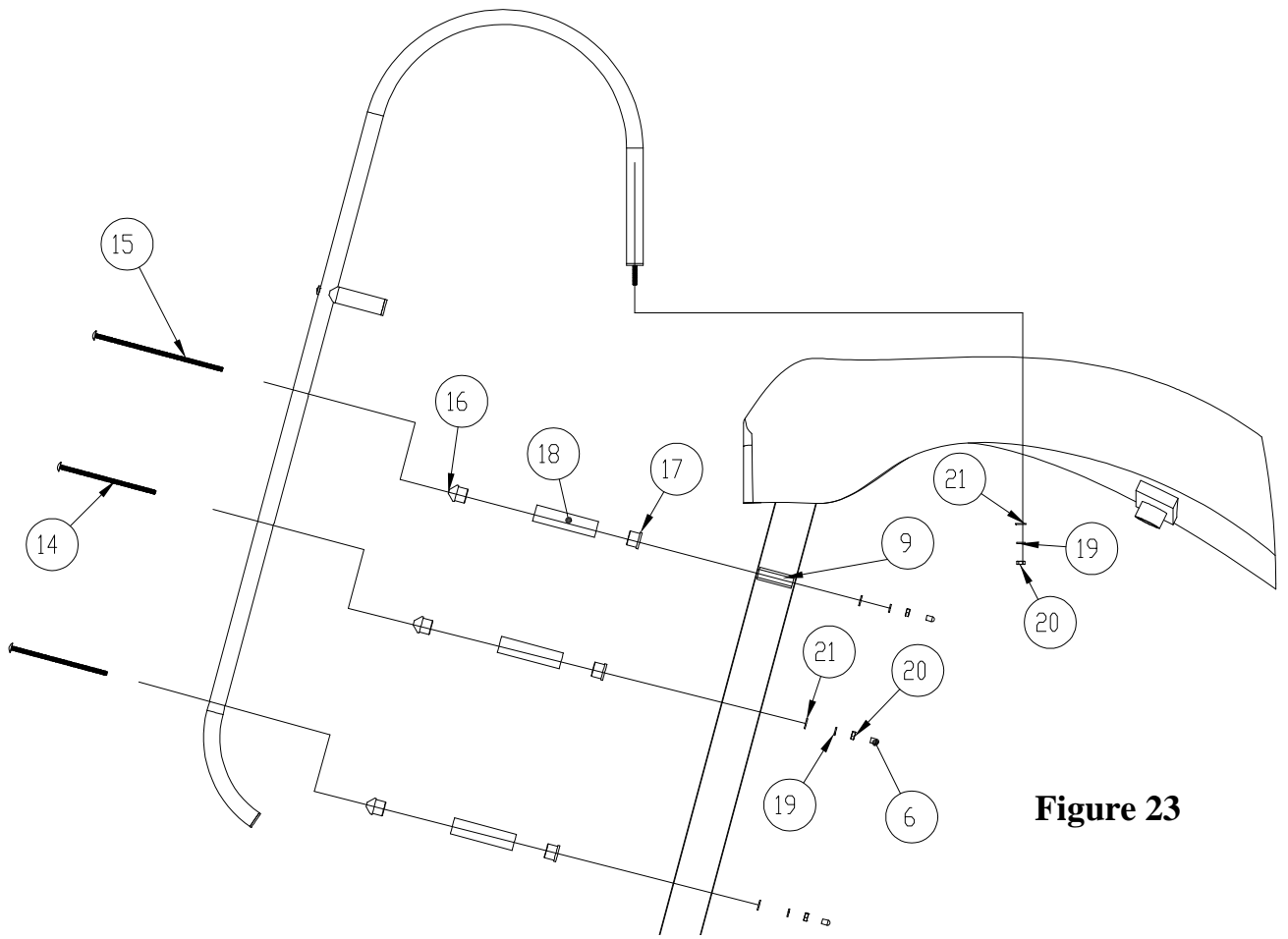
**Figure 21**

- 22)** If necessary the legs can be adjusted up and down within the leg sockets to help adjust for level. Once the slide is properly leveled the legs shall be permanently attached by drilling a 1/4" hole into each leg using the hole on the leg socket as a guide and fastening with a (#10) 5/16" Hex Head Washer Tek Head Screw. See Figure 22.

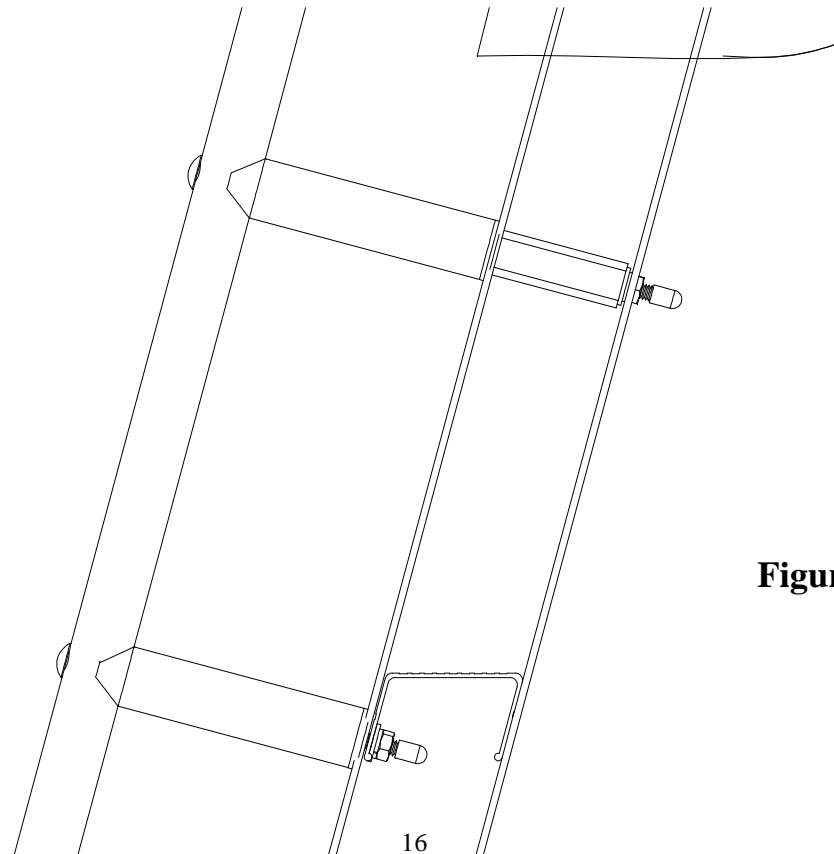


**Figure 22**

- 23)** Disassemble each handrail as shown in Figure 23. Insert the two handrails into the holes on the top of the slide runway rails, and secure each using a (#21) Flat Washer, a (#19) Lock Washer, and a (#20) Hex Nut.
- 24)** Starting with the top handrail spacer, align the top hole in the handrail with the top hole in the ladder side rail. Next, assemble the handrail spacer parts (#16), (#17) and (#18) in the order shown in Figure 23 and align it between the handrail and ladder top holes. Next, insert the (#15) 1/4-20 x 8" Carriage Bolt through the handrail and the handrail spacer parts. The (#9) Ladder spacer is to be placed in between the front and back sides of the ladder side rail such that the (#15) Carriage Bolt holds it in place after it is pushed completely through the ladder side rail, see Figure 24. Secure the (#15) Carriage bolt using a (#21) Flat Washer, a (#19) Lock Washer, and a (#20) Hex Nut in the order shown in Figure 23. Finally, place a (#6) Vinyl Bolt Cap over the exposed threaded end of the bolt.
- 25)** For the remaining two ladder spacers, align parts (#16), (#17) and (#18) between the hole in the handrail and the hole in the ladder as in step 24. Use a (#14) 1/4-20 x 6" Carriage Bolt along with a (#21) Flat Washer, a (#19) Lock Washer, and a (#20) Hex Nut to fasten the parts together as shown in Figures 23 and 24. Again, place a (#6) Vinyl Bolt Cap over the exposed threaded ends of the bolts.



**Figure 23**



**Figure 24**

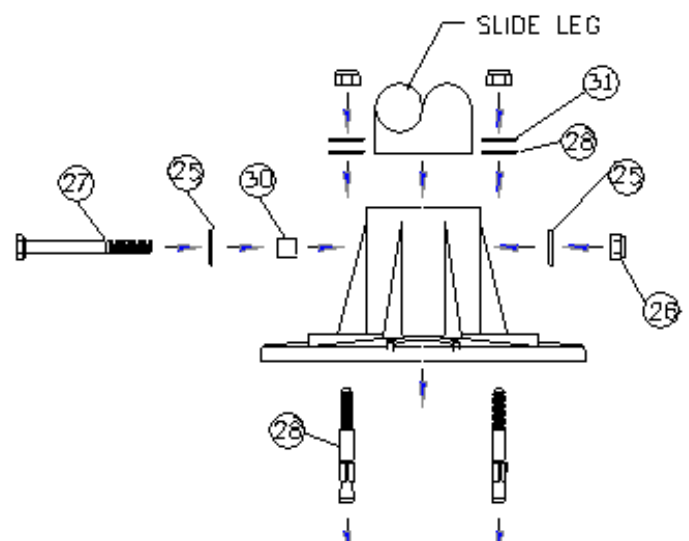


- 27) After connecting the water hose to ladder water connection, turn on water slowly to check for leaks.
- 28) Secure the slide, so that it will not move during the concrete pour, to ensure that the settings remain the same.
- 29) SUGGESTION: To ensure easy removal of concrete from legs and ladder, wax or wrap with wax paper approximately 12 inches above deck level.
- 30) Proceed with pouring the concrete deck and finish as desired. Let concrete cure 24 hours before using slide.

## **ASSEMBLY INSTRUCTIONS FOR FLUSH DECK MOUNTING**

The following instructions are for mounting a slide on an existing deck.

- 1) Follow the steps listed on the previous page for in-deck mounting, as they are the same with the exception of the attachment of the deck anchor flanges. NOTE: Rebar will not be used.
- 2) Place a deck anchor flange over each end of the slide legs.
- 3) Using the four holes on each flange as a template (see Figure 25 below), drill four 5/16" holes per flange 1-7/8" deep. CAUTION: Do not drill holes larger than 5/16". Maintain drill hole straight and perpendicular for proper holding strength of anchor stud.
- 4) Raise the flange up the leg and secure in place while using a hammer to drive the (#28) 5/16"-18UNC x 2-3/4" Anchor Stud, with a (#28) 5/16" Hex Nut on top, into the hole leaving 7/8 of an inch of the stud above the deck. Then tighten the nut until it is flush with the deck. Then, tighten the nut approximately three turns to set the anchor stud. Finally, remove the nuts.
- 5) Secure the four flanges with (#28) 5/16" Flat Washers, (#31) 5/16" Lock Washers and the (#28) 5/16"-18UNC Hex Nuts.
- 6) Using the holes on each ladder feet as templates, drill holes 5/16" diameter by 2-1/4 inches deep and secure (#28) Anchor Studs as described in 3 & 4 above.
- 7) Secure the two ladder feet with (#28) 5/16" Flat Washers, (#31) lock washers, and the (#28) hex nuts. Be sure that the ladder maintains 15 degrees from vertical.

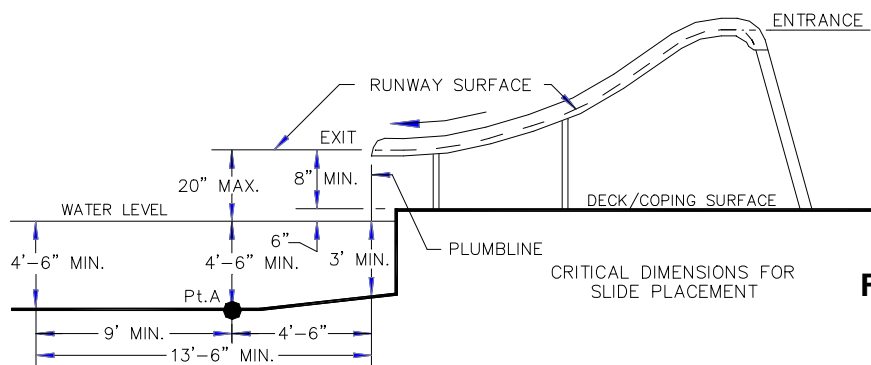


**Figure 25**

8) Drill a 1/4" diameter hole into the slide leg through the 3/8" diameter hole in the flange. Insert the (#30) 3/8" O.D. Aluminum Bushing into the hole in the deck flange and push in until it contacts the slide leg. Now insert the (#27) 1/4"-20UNC x 2-3/4" Hex Head Cap Screws and (#25) 1/4" x 5/8" Flat Washers through the bushing and in about a 1/2" into the hole in the slide leg. With the cap screw in position, drill a 1/4" hole into the slide leg through the 5/16" diameter hole in the opposite side of the deck flange. Take care not to run the drill bit into the 1/4" bolt. Push the cap screw completely through the slide leg. Install the (#25) 1/4" x 5/8" Flat Washers and (#26) 1/4"-20UNC Hex Lock Nuts (see Figure 25).

## MANUFACTURER'S PLACEMENT INSTRUCTIONS

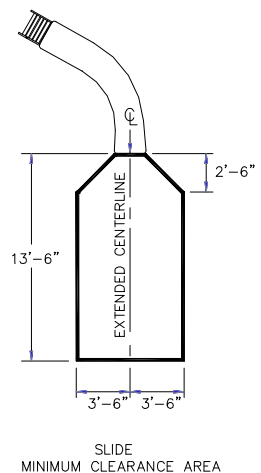
- 1) The critical dimensions for placement of the slide are as shown in Figures 26 and 27.
  - A. The slide exit runway surface shall not exceed twenty inches (20") above the water surface and not less than eight inches (8") above the deck/coping surface (see Figure 26).
  - B. The slide shall be positioned so that all water flowing off the runway exit drops into the pool.
  - C. The minimum depth of water below the exit lip of the slide shall be three feet (3') and increases to four feet six inches (4'-6") at Pt. A which is a distance of four feet six inches (4'-6") from the exit lip of the slide. (See Figure 26).
  - D. A minimum depth of four feet six inches (4'-6") shall be maintained at a distance of nine feet (9') along the extended centerline of the slide from Pt.A. (See Figure 26).



**Figure 26**

2) A minimum clearance area in front of the slide shall be maintained away from the coping, another slide, a diving board or a rope and float line. (See Figure 29)

- A. The minimum clearance distance on either side of the extended centerline of the slide runway shall not be less than three feet six inches (3'-6") at a point no less than two feet six inches (2'-6") from the exit of the slide and extending a distance of thirteen feet six inches (13'-6") in front of the slide. (See Figure 27)



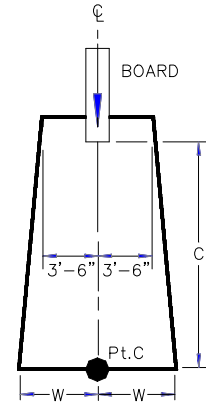
**Figure 27**

B. The minimum clearance area in front of a diving board is a minimum distance of three feet six inches (3'-6") on either side of the board's centerline. Pt.C extends a minimum distance of "C" from the tip end of the board. The width distance "W" on either side of Pt.C is given in CHART 1 and shown in Figure 28.

**CHART 1**

BOARD MINIMUM CLEARANCE AREA		
POOL TYPE	"C" DIMENSION	"W" DIMENSION
I	14'-6"	5'-0"
II	14'-6"	6'-0"
III	16'-6"	6'-0"
IV	18'-6"	7'-6"
V	21'-0"	7'-6"

See Article 5 contained in ANSI/APSP/ICC -5 2011 STANDARD FOR RESIDENTIAL INGROUND SWIMMING POOLS and refer to Figure 3 and Table 1 for Minimum Water Envelope Dimensions AB, BC and Width at Point C.



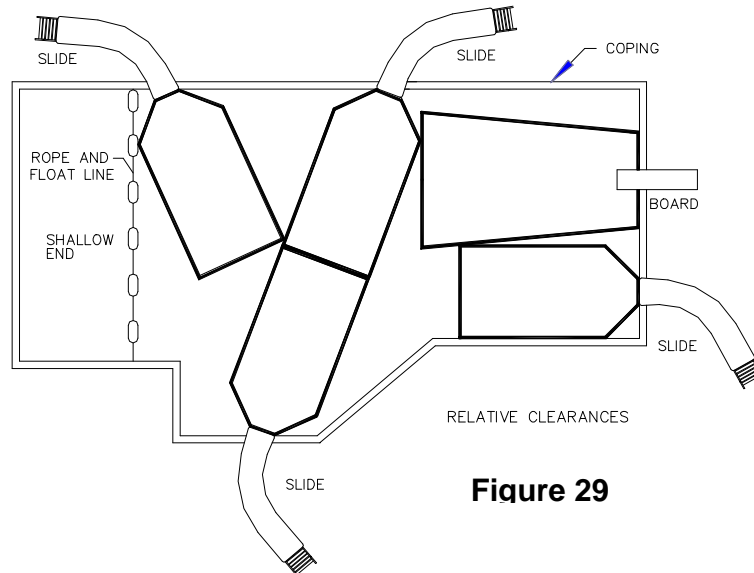
BOARD  
MINIMUM CLEARANCE AREA

"C" DIMENSION FOR BOARD = AB + BC

"W" DIMENSION FOR BOARD = WIDTH AT PT.C

**Figure 28**

C. The minimum clearance area of a slide or diving board shall not intersect any coping or rope and float line. (See Figure 29) The minimum clearance area of a slide or diving board may intersect each other provided that they are not used simultaneously.



**Figure 29**

## **ELECTRICAL BONDING**

If electrical bonding is required by the local governmental regulations, it shall be done in accordance with Article No. 680 of the current National Electrical Code or the local Code, whichever has jurisdiction. Five (#22) 1/4" x 1/2" Sheet Metal Screws and five (#23) 1/4" x 3/4" Flat Washers are provided for this purpose. Secure one per slide leg and one per ladder.

## **INSTALLED SLIDES' STRUCTURAL & INSTALLATION CHECKLIST**

- 1) Inspect the runway for visible cracks or tears.
- 2) Inspect the slide for sharp edges, protrusions, cracks or tears.
- 3) Inspect all attachment flanges for loose or corroded fasteners.
- 4) Inspect all ladder tread or step-attachment points for evidence of shear, bending yield, or fatigue in the ladder steps, rails, or attachments means. Yield is evidenced by crystallization or fine cracking of the ladder tread and/or surface.
- 5) Inspect the ladder handrails for rigidity and attachment. (Can they be pulled out of their sockets?)
- 6) Measure the following dimensions and compare with the Manufacturer's Placement Instructions on pages 18 and 19. Also review the ANSI/NSPI-5 2003 STANDARD FOR RESIDENTIAL INGROUND SWIMMING POOLS.
  - Measure the depth of water in front of the slide exit. (4-1/2' min. depth 4-1/2' from exit end of slide.)
  - Measure the height of the slide runway exit above the water. (20" max.)
  - Measure the distance between the slide centerline and the edge of other pool equipment.
- 7) Observe the position of the exit of the slide as shown in Figures 26, 27 and 28 on pages 18 and 19.

## **IMPORTANT**

**PERSONALLY GIVE TO SLIDE OWNER THE ROGUE™ GRAND RAPIDS™ OWNER'S MANUAL, THE WARRANTY CARD AND ANSWER ALL QUESTIONS.**